



OWNER'S MANUAL



INDUSTRIAL/COMMERCIAL EVAPORATIVE AIR COOLERS

S/D89PUE
US/UD940
US/UD950



U/D/S88PUE
EU/ED/ES143
EU/ED/ES213



Owner's Guide
Installation | Operation | Servicing | Maintenance

NOTE!
Read And Save These Instructions—
“Important Safety Instructions”



Note to Installer:
Please deliver this guide to
the owner.

⚠ Caution:
Read all instructions
carefully before instal-
lation.

Installation & Start-up

Your air cooler was thoroughly tested and inspected before leaving the factory. This is your guide to economical, trouble free comfort cooling over the years with reasonable care and regular maintenance. **READ IT CAREFULLY.**

WARNING: To reduce the risk of fire, electric shock, and injury to persons, evaporative air cooler must be installed with pump and motor that are marked on their labels to indicate the suitability with this model. Other pump and motor cannot be substituted.

Caution: Disconnect all electrical power of the cooler before attempting to install, open, or service your cooler. If your cooler is thermostatically controlled, the thermostat is not to be used as a disconnect as it may rest and start the unit unexpectedly.

Caution: Do not allow pump to topple over and become submerged; water will damage pump motor.

Note: Your warranty does not cover shipping damage. Report all shipping damage at once to dealer or carrier making delivery.

Even while routinely inspecting or servicing the inside, the cooler can be accidentally started. Keep all personnel away from the cooler and electrical supply when you are working on it.

Don't attempt to perform any part of the installation described in this book unless you are fully qualified to do so. All electrical work must meet local codes and national codes (N.E.C.) and must be performed by qualified person only.

Before attempting to install the cooler, make sure the following preparations have been made:

- Assure that the mounting surface is strong enough to bear the weight of the cooler when use; remember that when the system fills with water, the cooler will be much heavier than when dry. For operating weight, see accompanying part list.

- Make sure you have adequate means for lifting the cooler in place.
- Check the electrical supply to see that it matches the requirements shown on the motor name plate.
- Make sure the mounting surface is level in all directions.
- Make sure and ductwork and electrical need comply with local and national codes.

Caution: Do not exceed maximum amperage output as stamped on the motor specification plate or motor can overload. Only qualified persons with proper electrical equipment and knowledge should adjust variable pitch sheaves. Do not allow water to get on the motor, as it will burn out the windings.

Caution: Disconnect all electrical power to the cooler and insure that belt is not rotating before adjusting belt tension. Do not adjust the belt tension only by adjusting motor bracket.

Location:

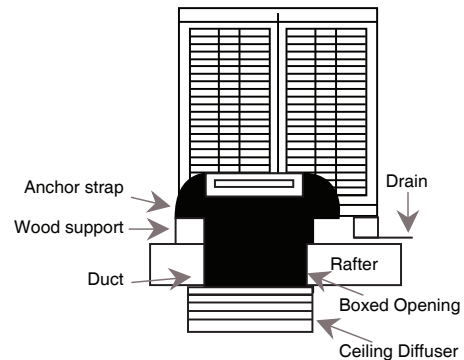

Figure 1

Down discharge commercial and industrial cooler are designed for installation on either flat or pitched roofs (see Figure 1). Side discharge coolers are designed for installation on the side of a building (see Figure 2), or they may be installed on a roof by using a transition duct from cooler opening to building duct (see Figure 4).

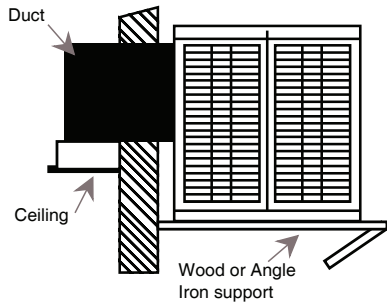

Figure 2

Commercial and industrial coolers are usually connected to a duct system or ceiling diffuser for air distribution throughout area being cooled. Install cooler so only fresh outside air enters cooling system. Avoid installing unit in closed-in areas, such as an attic or storeroom, which restrict free air movement around cooler. Avoid installation near ventpipes, kitchen exhaust, etc. as odors or fumes may be drawn into unit. When coolers are installed on roof to cool large rooms such as factories, auditoriums or supermarkets, divide cubic area of room and strategically locate units of proper capacity to cool divided areas. Install straight duct from roof to ceiling and use ceiling diffusers to distribute air throughout area (see Figures 1 and 3).



Caution: All electrical installations must comply with local building and safety codes and must be performed by qualified personnel only.

»» Duct system

Air can be delivered over a distance to individual rooms or areas by means of a duct system. The duct system, which is tailored to fit the building, should be fabricated and installed by a competent sheet metal contractor, preferably while building is under construction. A typical duct system consist of a main duct with same dimensions, or larger, than blower opening of cooler, and duct branches which are sized according to cubic area of rooms to be cooled.

Correct cooler size is determined by dividing desired number of minutes air change into total cubic feet of building. Example: A building with an inside area of 30,000 cubic feet, using air change every two minutes, would require one 15,000 CFM cooler or two 7,500 CFM coolers. The size of duct opening in each room is determined by multiplying the square inches of cooler

blower opening by two and dividing area proportionally to room size.

Reduction on side of duct immediately after a branch acts as an air scoop for branch acts as an air scoop for branch take-off. On ducts using square corners, turning vanes are desirables for free air flow around corners and duct branches. To control volume and direction of air in individual rooms, registers with adjustable or fixed louvers are attached to ends of duct branches.

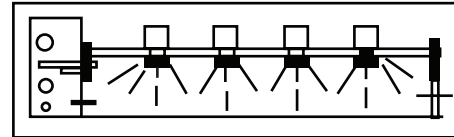

Figure 3

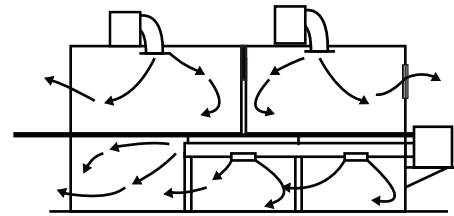

Figure 4

»» Air exhausting

Windows or doors at point most distant from cooled air inlet should be left open to permit free movement of air out of area being cooled, and avoid building up static pressure. Proper location of exhaust openings is important as they guide flow of air through areas where cooling is desired. Using standard CFM ratings, a common method for determining how much to open door or windows for proper exchange is 2 square feet unrestricted per 1,000 CFM.

»» Electrical Installation

»» Electrical power

Be sure cooler is connected to proper line current, voltage and cycle as stamped on cooler motor and pump motor specification plate. Check with local power company is in doubt.



Caution: All electrical installations must comply with local building and safety codes and must be performed by qualified personnel only.

impco.



Note: Improper voltage will void motor guarantee.

The horsepower, voltage, cycle, phase, current, number of speed of motor and length of wire required from switch to motor will determine the gauge of wire to be used.

Larger horsepower and three-phase applications require switches and/or starters of proper current capacity and should be installed by a competent electrician.

»» Electrical Ground

For maximum safety precaution, make sure cooler cabinet is properly grounded to a suitable ground connection.

»» Motor Installation



Caution: Disconnect all electrical power to the cooler before attempting to install, open, or service your cooler. If the cooler is thermostatically controlled, the thermostat is not to be used as a disconnect as it may reset and start the unit unexpectedly.

- Install motor using four carriage bolts provided.
- Check motor mounting to be sure all screws and nuts are tightened down.
- Wire motor for proper rotation. See arrow on blower housing.
- Insert sheave onto motor shaft.
- Insert pulley onto the blower shaft.
- Rotate blower wheel by hand to see that it moves freely without rubbing against housing.
- Install belt from motor sheave to the blower pulley.
- Align belt by vertically centering motor pulley in-line with blower pulley (see Figure 5)

»» Adjustable Motor Pulley

When cooler is connected to extended ductwork, the cooler capacity and motor amperage may decrease due to duct resistance. The adjustable motor pulley is used ONLY to return cooler and motor to maximum load capacity and should not be readjusted except for

this purpose.

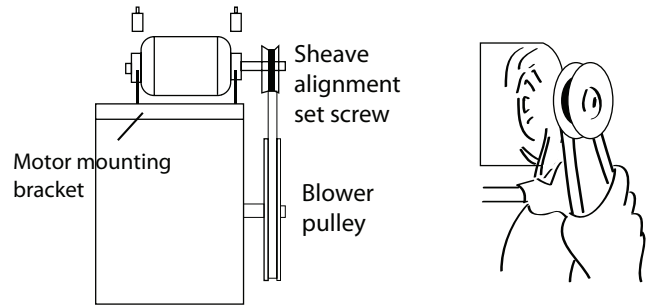

Fig. 5



Caution: Do not exceed maximum amperage output as stamped on the motor specification plate or motor can overload. Check amperage with all windows and doors open and all relief system operating. Improper pulley adjustment will overload and burn out motor. Only qualified persons with proper electrical equipment and knowledge should adjust variable pitch sheaves.



Caution: Never operate unit with service panels, media or inlet panels removed. This will result in an overloaded condition and may damage the blower motor.

»» Belt adjustment



Caution: Disconnect all electrical power to the cooler and insure that belt is not rotating before adjusting belt tension. Do not adjust belt tension by changing diameter of adjustable sheave. Adjust belt tension only by adjusting motor bracket.

Correct belt tension alignment is important as it cuts power consumption and prolongs life of belt and motor. When installing or adjusting belt, loosen the motor adjustment bolts and adjust for proper tension for each model as listed below. Do not tighten belt by adjusting motor pulley. Align belt vertically by centering motor pulley in-line with blower pulley (see Figure 5).

Motor HP	Belt Tension
3/4	25 lbs
1	25 lbs
1-1/2	25 lbs
2	25 lbs
3	35 lbs
5	35 lbs
7-1/2	40 lbs

»» **Install Overflow Standpipe and Drain Line**

Install overflow drain bushing in bottom of cooler. Slide rubber washer over drain bushing, push drain bushing through bottom of cooler, and tighten nut. Screw plastic overflow standpipe into the drain bushing and tighten snugly to prevent leakage. Connect a drain (copper/pvc/garden hose) to drain bushing and drain in accordance with local codes (see Figure 6).

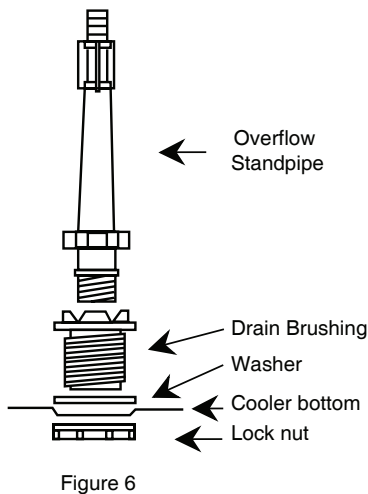

Figure 6

»» **Connect water supply**

Caution: All plumbing installations must comply with local building and safety codes, and must be performed by qualified personnel only.

Connect water line to cooler as follows (see Figure 7): A water valve should be installed at a convenient location, to allow the water supply to be turned on and off. 1/4" tubing is used to provide water to the cooler. Install float valve in the side panel of the wet section near the blower service panel. Place tube nut and ferrule over end of tubing. Connect 1/4" pipe from water supply to float valve.

Insert tube into float valve, and tighten to secure.

Note: Copper tubing supply line (5/16" dia.) may be substituted by using a standard street elbow (1/4" pipe thread x 5/16" tube) purchased locally (see Figure 8).

Note: Soft water equipment should not be attached to any water lines going to a cooler. "Soft water" will cause corrosion and decrease effective life of cooler.

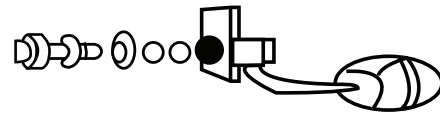

Figure 7

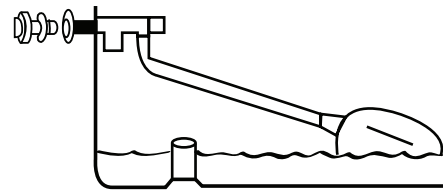

Figure 8

»» **Recirculating Pump**

Recirculating pumps are necessary for Industrial cooler operation.

Caution: Do not allow pump to topple over and become submerged; water will damage pump motor.

»» **Mounting Pump**

Install pump in a convenient place out of the main air flow stream, where distribution tube will reach pump discharge.

»» **Install Bleed-off**

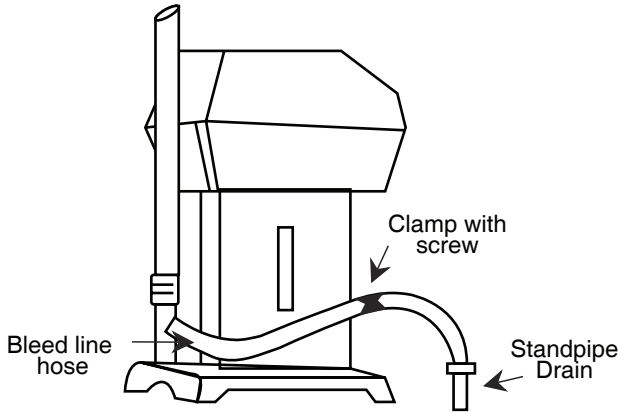

Figure 9

To minimize scale “build-up” we recommend the use of a bleed-off assembly, available for purchase*.

* For models D/S89PUE 940 y 950 Bleed off system has been provided.

This bleed-off assembly merely requires inserting the bleed-off hose into the pump assembly and routing the bleed line through standpipe opening (see Figure 9). Install as follows:

- Install bleed line into pump assembly bleed-off tap.
- Route far end of bleed line into standpipe.
- Install clamp with screw on bleed line.
- Adjust screw to obtain flow rate for appropriate model indicated on following page.
- Water to be drained in accordance with local codes.



Note: Bleed rate may degrade slightly after two weeks and should be checked two to four weeks after initial setting and readjusted.

Models	Motor HP	Gallons per Hour (Recommended)	Adjust clamp to bleed-off this 12 oz. container (beverage can) in the time shown (seconds)
S88PUE	3/4	6.1	56
D88PUE	1	6.7	50
S89PUE	1-1/2	7.7	45
D89PUE	2	8.4	40
	3	9.6	35
	1	8.9	38
ED/ES143	1-1/2	10.2	33
US/UD940	2	11.1	30
	3	12.8	26
	1-1/2	12.9	26
	2	14.1	24
ED/ES213	3	16.2	21
US/UD950	5	19.2	18
	7-1/2	20.9	16

»» **General Inspection**
Start-up Inspection



Caution: Disconnect all electrical power to the cooler before attempting to install open, or service your cooler. If the cooler is thermostatically controlled, the thermostat is not to be as a disconnect as it may reset and start the unit unexpectedly.

Before starting the cooler motor and pump to check out operation, make sure all installations and adjustments have been properly and thoroughly made. Assure that:

- Cooler mounting is level; duct is sealed.
- Cabinet is securely fastened to mounting.
- Cooler cabinet is grounded. Electrical connections are safe and secure.
- Motor, pump, and float installed.
- Pump impeller turns freely. Remove pump and basket.
- Remove impeller cover (see Figure 10) and spin the impeller to assure free rotation.
- Water lines connected securely without leaks. Water supply turned on.
- Float adjusted for proper water level.
- Blower, shaft, collar, and pulley set bolts are snug (do not overtighten pulley bolt).
- Pulley alignment okay; belt tension okay.
- Blower bearings are lubricated. Fill oil cup with a good grade SAE 20W or 30W.
- Pads presoaked and correctly installed.

»» **Start-up Check list**

To check out installation, and initial start-up procedure should be followed.

- Turn electrical supply on.
- Check to see that pump starts and pads are evenly wet.
- Open windows or vents in building.
- Start blower by switching to cooling mode.
- Check for cool air delivery.

In case of trouble in any of these, refer to the troubleshooting chart on page 14.

»» **CLEANING AND INSPECTION**

For maximum efficiency and longer life the cooler should be inspected and cleaned every two months. All foreign materials, scale, salt deposits, lime, etc. can

and should be removed from louvers or inlet screens, bottom pan, and other components. Your cooler’s long lasting finish can be brought to like-new condition by using warm water and soft cloth. Do not clean fan motor with this method. Motors damaged by water are NOT covered under warranty. Avoid scouring pads, steel wool, and wire brushes, as these will damage the finish and encourage corrosion.

»» **Cabinet inspection Checklist**

Refer to the troubleshooting chart if necessary.

- Check for leaks.
- Check to see that the cooler is level.
- Check cooler pads for uneven wetting.
- Check water level.
- Check water distribution system for full even flow.
- Rotate blower wheel for free movement.
- Align belt.
- Check belt tension and condition.
- Check that set screws and nuts on pulleys, blower wheel and collars are tight.

»» **Maintenance Schedule**

Regular maintenance is a key to long successful service of your industrial cooler. The service will help you maintain an efficient unit with good appearance. Regular, careful maintenance will allow you to enjoy a long, more efficient service life from your cooler. Before starting any maintenance operation, read thoroughly, all operating and maintenance instructions and observe all cautions and warnings.

Maintenance	Page	Annual start-up	During Season	Annual Shut-down
Cabinet Inspection	4	•	•	
Changing cooler Pads	5	•	As req’d	
Lubrication	5	•	•	•
Adjusting Belt Tension	5	•	•	
Cleaning Water Pump	5	•	•	
Cleaning & Touch Up	5			•
Drain All Water Lines	5			•



Note: Do not undercoat the water reservoir

Your cooler’s water reservoir is finished with a Poly-

bond appliance-type finish. It is so hard that asphalt-type cooler undercoating will not stick to it. Undercoat will break free and clog pump and water distributor.

Use chemical additives or any water treatment other than bleed-off is not recommended for this cooler.

»» **Cleaning & Inspection**

For maximum efficiency, longer life and appearance, every two months during operation the cooler should be inspected and cleaned. All foreign materials, scale, salt deposits, lime, etc. can and should be removed from louvers, bottom pan, and other components. Your cooler’s long lasting finish can be brought to like-new condition by using warm water and soft cloth.



Note: Do not clean blower motor with this method. Motors damaged by water are NOT covered under warranty, Avoid using scouring pads, steel wool and wire brushes, as these will damage the finish and encourage corrosion.



Caution: Never wash the inside of your cooler cabinet with a garden hose; water may harm motor and pump or seep into ductwork.



Important: Before operating cooler at beginning of each cooling season, turn blower wheel, cooler motor and pump motor shafts by hand to make sure they turn freely. Failure to do so may results in burning out motor.

»» **Maintenance**

Regular, careful maintenance will allow you to enjoy a long, more efficient service life from your cooler. Before starting any maintenance operation, read thoroughly all operating and maintenance instructions and observe all cautions and warnings.

»» **Pad Cleaning instructions**

Do not use high psi spray washers or steam cleaners to remove these deposits.

»» Periodic Inspection

In addition to the planned maintenance schedule, periodic inspection of your Industrial Cooler will enhance the chance for long, trouble-free service life.

»» Check for leaks

Are there any dry spots on the media when cooler is in operation?

Are bolts, nuts and set screws snug?

Is cooler level?

Does blower turn freely?

Is float set correctly?

Is water pan clean?

Proper belt tension?

»» Adjust Belt Tension

Each time you inspect your cooler, be sure to check belt tension on motor/blower assembly. Check belt condition and replace it if frays or defects appear. Check alignment of blower pulley with motor pulley.

»» Cleaning Water Pump

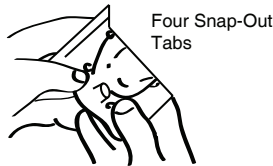
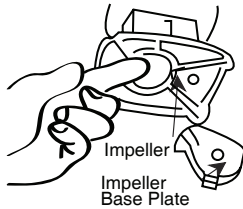

Figure 10



Disassemble and clean water pump as follows (see Figure 10):

1. With power supply disconnected, unplug pump cord.
2. Remove pump
3. To prevent breakage, carefully release the four snap-out tabs, and lift impeller base plate from the pump body.
4. Using a mild detergent solution, wash all deposits from inside around impeller and impeller base plate.
5. Spin impeller to dislodge any foreign material.
6. Rinse and reinstall impeller base plate.

7. Reinstall pump.

8. Connect cord.



Caution: Disconnect all electrical power to the cooler before attempting to install, open, or service your cooler. If the cooler is thermostatically controlled, the thermostat is not be used as a disconnect as it may reset and start the unit unexpectedly.



Caution: Do not allow pump to topple over and become submerged; water will damage pump motor.

»» Snugging Down Set Screws and Nuts

Set screws and hardware that should be snugged down:

- Pulley set screws (95 in-llbs)
- Blower set screws (2) (150 in-llbs)

»» Lubrication

Motor Bearings

The motor bearings are oiled at the factory, but should be checked before operating cooler. If need for oiling is indicated, use any good grade SAE 20W or 30W oil. Apply 2 or 3 drops of oil into each oil cup on cooler motor. Under normal use, oiling is required about every three months of operation. Do Not Over-Oil.

»» Blower shaft Bearings

Blower shaft bearings need periodic lubrication. The oil cups on the blower shaft bearings should be filled with good grade SAE 20W or 30W oil when necessary. Under normal use, oiling is required every three months of operation. Do Not Over-Oil. The pump motor does not require lubrication.

»» Changing Cooler Pads

Your cooler pads should be changed at least twice a year...at the beginning of a season and midway through.

But your pads may need to be changed more frequently, depending on local air and water conditions. For instance, in areas where mineral content of the water is high, deposits may build up in the cooler pads, restricting air flow.

Replace pads as follows:

1. Remove pad assembly from cabinet.
2. Remove pad frame stiffener from frame, using caution as stiffener can spring back. Carefully remove all aspen from retainers. Remove and clean pads.
3. Using a mild detergent, wash dirt and scale from pad frames. Wire brushing is not recommended. Rinse with fresh water.
4. Lay new pad in frame, starting at trough end, making sure pad is snug against trough and outer edges with no air spaces.
5. Pad thickness should be uniform across the frame. Note: Pad must completely fill frame or hot air may enter building.
6. Replace pad retainers and lock under edge of frame. Sharp points must be buried in pad.
7. Pre-soak pads and reinstall pad frame.
8. Start pump and allow through to fill...check water level in through by slightly each pad frame out.

Fig. 12

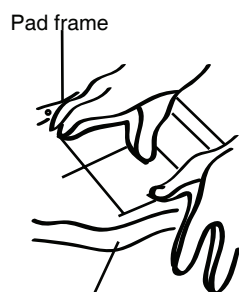

Evaporative media

Press retainer wires down to clear frame

Fig. 13

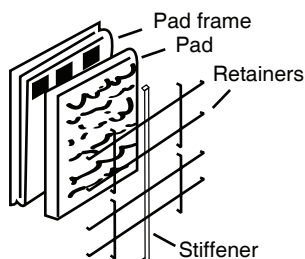

Caution: Disconnect all electrical power to the cooler before attempting to install, open, or service your cooler. If the cooler is thermostatically controlled the thermostat is not to be used as a disconnect as it may rest and start the unit unexpectedly.

» Draining

Drain the cooler cabinet (with power off and panels removed) as follows:

Connect a drain hose to the drain fitting on the bottom of the reservoir

Remove standpipe from the drain fitting.

Drain and clean reservoir (never drain water onto a roof)

» Touch-up

The hardness, adhesion and smoothness of the internal and external finish on your cooler makes it extremely unlikely that scratches or chipping will occur. In the event that finish damage does occur, it should be promptly repaired by the following procedures.

1. Sand the area around bare metal spots.
2. Prime and paint with a quality paint.



Note: Do not undercoat the water reservoir.



Important: Before operating cooler at the beginning of each cooling season, turn blower wheel, cooler motor and pump motor shafts by hand to make sure they turn freely. Failure to do this may result in burning out motor.

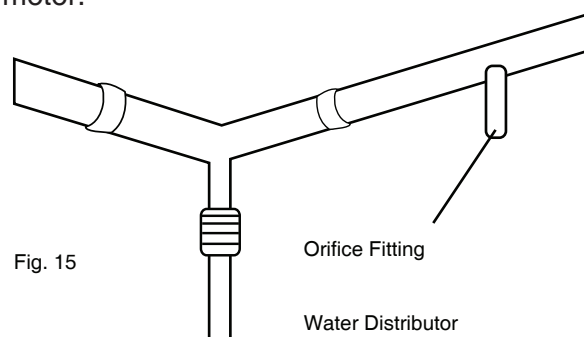

Fig. 15



Important: Do not remove orifice fittings from water distributor tubes unless replacement is necessary (see the figure 15).

Do not use asphalt type cooler undercoat material in the water reservoir.

» Getting the most from your cooler

Your evaporative cooler is finely crafted, economically operating unit built on decades of know-how and research. It serves as the heart of an overall air cooling and moving system for a building.

But there are a number of ways you can maximize the comfort, efficiency, economy and convenience of your total cooling system.

» Maintenance

Regular maintenance as recommended in this manual is essential for cooling comfort, extending the life of your cooler, and avoiding unnecessary parts replacements. Start-up, mid-season and shut-down servicing

impco.

should never overlooked. Change pads at least twice a year, or sooner, if mineral deposits or dust build-up.

»» Bleed-off

Bleed-off components are available for each cooler and should be installed as instructed in this manual.

»» Replacement parts

When ordering replacement parts, always refer to the serial and model number of your cooler. Use the part numbers listed in the accompanying part list, as illustrated in the diagrams for your model.

»» General Wiring Instructions

All installations should be done in accordance with National Electric Code, (N.E.C.) Article 110.

»» Safety Disconnect switch(es)

Shall have minimum enclosure classification compatible with the installation location and installed in accordance with N.E.C., Article 430. The disconnect switch shall be a U.L. Listed disconnect which breaks all undergrounded conductors that can carry current to the unit.

»» Over-current (short circuit) Protection

Devices intended to protect the motor branch-circuit conductors, motor control apparatus and motors against overcurrent due to short circuits or ground faults shall have minimum enclosure classifications compatible with the installation location and installed in accordance with N.E.C., Articles 240 and 430. These devices shall be U.L. Listed short circuit protection devices and sized in accordance with specifications as stated in N.E.C., Article 430.

»» Overload protection

All single phase motors available from Impco, Inc. for use in industrial/commercial units have integral thermal overload protection (running and locked rotor). All 3-phase motors require overload protection, sized and installed in accordance with N.E.C., Article 430 (see motor starter).

»» Motor Start Switch

In applications where a switch is adequate to start the motor, as defined by N.E.C., Article 430, the branch circuit shall be sized in accordance with N.E.C., Article 210 and 430. The enclosure for the switch and its lo-

cation shall comply with N.E.C. requirements for the installation of the switch. A switch kit is available from Impco for use with 120 or 240 volt, 1 or 2 speed single phase motors.

»» Motor Starter

Device with integral thermal overload protection used to start/stop 3 phase motor. Motor start shall be sized in accordance with specifications as started in the N.E.C. Article 430. A general recommendation for sizing the starter is tabulated on a label attached to the blower housing of each unit. Starters mounted to the unit shall have minimum NEMA 3R (raintight-rainproof) enclosure rating. Starter mounted remote to the unit shall have minimum enclosure classification compatible with the installation location and installed in accordance with N.E.C., Article 430.

»» Control Circuit Transformer

Shall be N.E.C. class 2 transformer of adequate capacity and installed in accordance to national and local codes.

»» Pump transformer

When required, transformer shall have a minimum ampacity of 250 VA and have, or be located within, a minimum enclosure classification compatible with N.E.C., Article 450.

»» Pump Circuit

The pump circuit, if not operating on a transformer, shall have overcurrent protection of 15 AMP or smaller and have a minimum of #14 AWG copper wire to the pump receptacle. The pump receptacle shall be a Ground Fault Circuit Interrupter (G.F.C.I.) type receptacle or protected by a G.F.C.I. type circuit breaker and shall be mounted in a outside type (NEMA 3R, rain-tight-rain proof) box and cover. The recommended location for the receptacle box to be attached to the unit is shown on page 8 of the Owner's Guide. Conduit to the receptacle box shall be rain-tight or liquid-tight, flexible metal conduit with separate ground wire, installed in accordance with N.E.C., Article 351.

Wiring diagram • Power Supply Cross Reference		
Power Supply	Control Circuit	See Wiring Diagram
120 Volt/ 1 Phase	120 volt in-line switch	"A"
120 Volt/ 1 Phase	24 Volt relays & control Thermostat	"C"
208 or 240 Volt /1 Phase	240 Volt in-line switch	"B"
208 or 240 Volt /1 Phase	24 Volt relays & Control Thermostat	"D"
208, 240 or 480 Volt 3 Phase	120 Volt relays & in-line switch	"E"
208, 240 or 480 Volt 3 Phase	240 Volt relays & in-line switch	"F"
208, 240 or 480 Volt 3 Phase	24 Volt relays & Control Thermostat	"G"

Symbol Legend	
See general wiring instructions for description/requirements of components.	
SD1	Safety disconnect, motor/pump circuit
SD2	Safety disconnect, pump/motor circuit on separate power supply
FB1	Overcurrent (short circuit) protection device, fuse or inverse-time circuit breaker sized for motor circuit (per N.E.C.)
FB2	Overcurrent (short circuit) protection device, fuse or inverse-time circuit breaker (G.E.C. I. Type) sized 15 AMP or less for pump/control circuit (per N.E.C.)
SW1	Motor start/stop (on/off) switch
SW2	Pump switch (cool/vent)
SW3	Motor speed switch (low/high)
R1	24V control relay, motor on/off
R2	24V control relay, pump, cool/vent
R3	24V control relay, motor speed, low/high (NO/NC)
MS	Motor starter, control relay w/thermal overload.
MP	Media pump, EP280A (120V) or EP48A (240V)
XFMR1	Control transformer, 120, 208/240 or 480V primary/24V class 2 secondary
XFMR2	Pump transformer, 208/240 or 480V primary /120V secondary, 250VA minimum
BLWR MTR	Blower Motor: Single Phase- 1 or 2 speed thermally protected, three phase-not thermally protected, use appropriately sized motor starter w/thermal overload protection N.E.C. requirements.
PR	Pump receptacle, ground fault circuit interrupter (G.F.C.I.) type receptacle or protected by a G.F.C.I. type circuit breaker. Mounted in a weatherproof box with cover

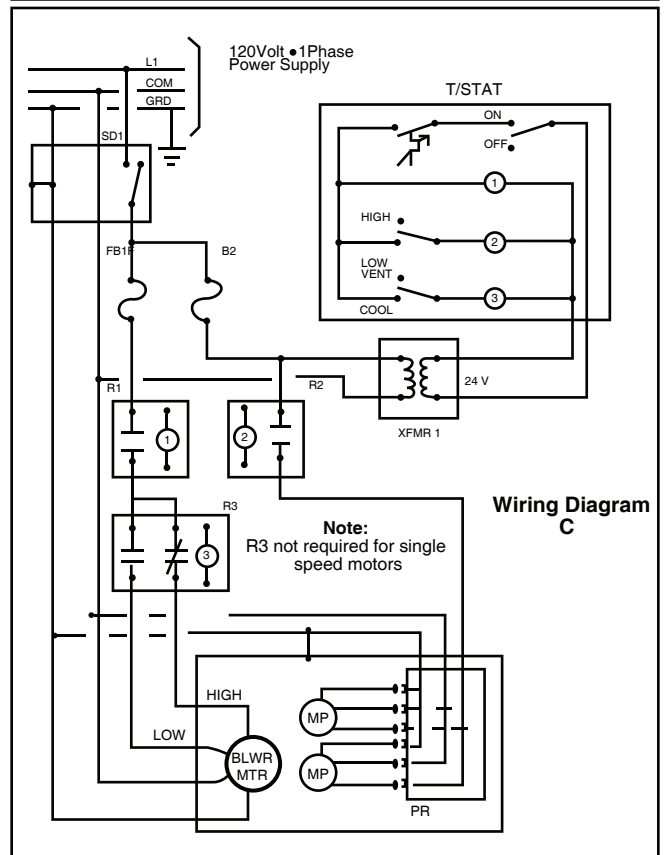
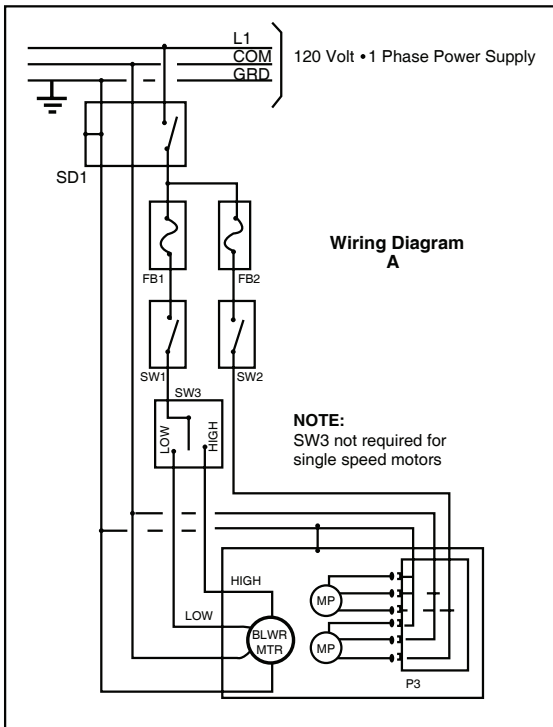
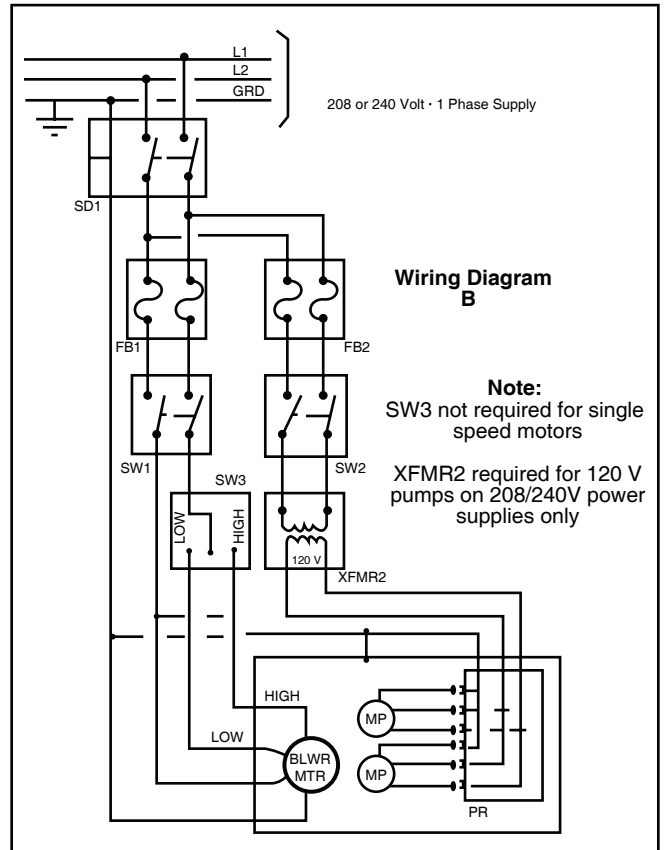

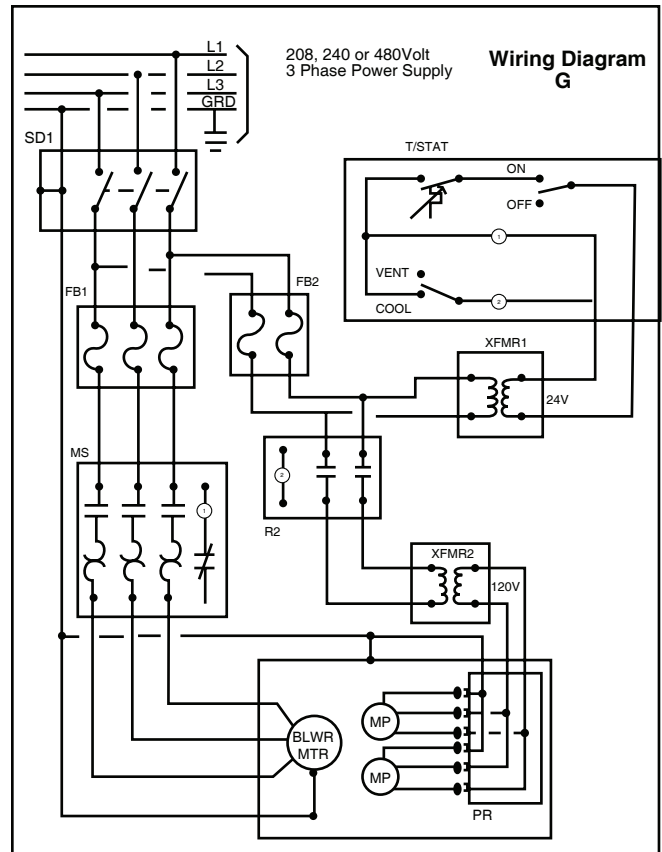
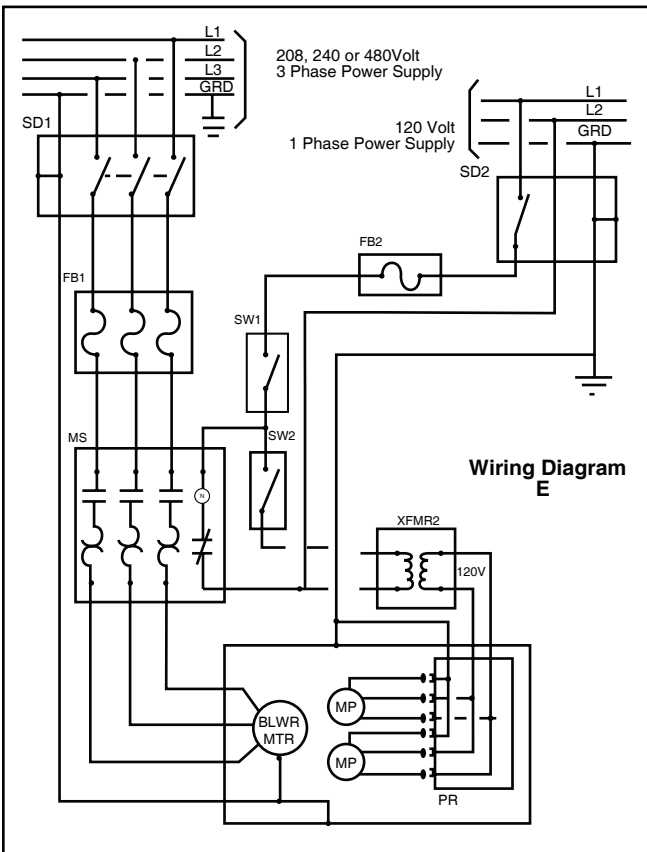
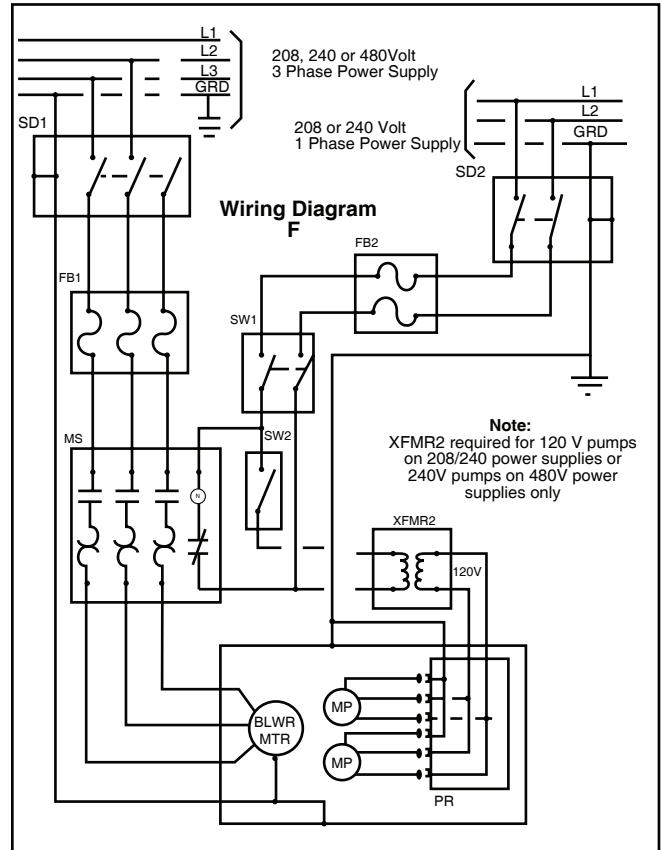
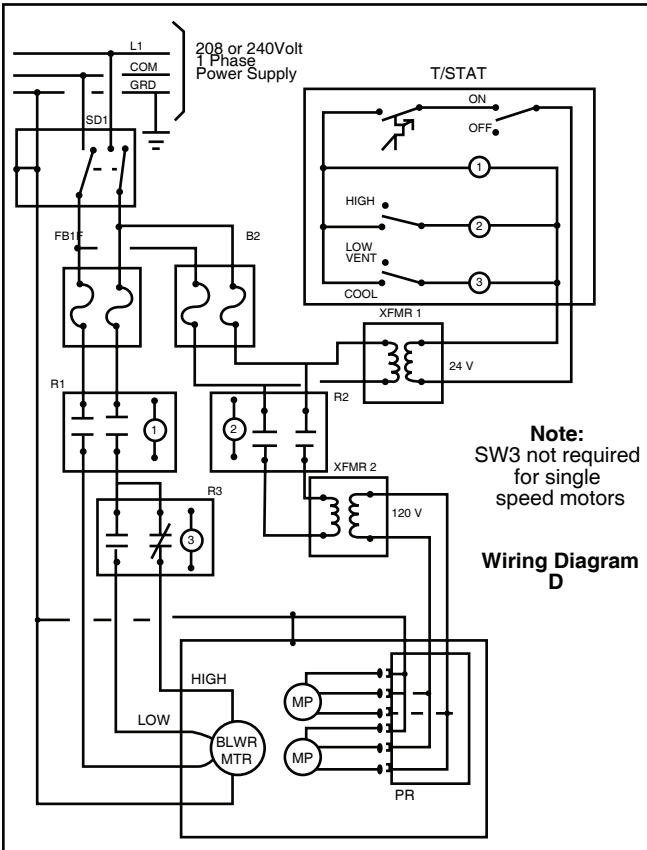

» Notes

1. Wire clip (approximate location)
2. G.F.C.I. protected receptacle in weatherproof box with cover. Use pre-drilled holes on blower housing to locate box as indicated.
3. To control panel (pump circuit)
4. Pump location and mounting procedure.
 - Disconnect electrical power to cooler prior to pump installation.
 - Position pump as shown for your specific model, making sure pump is sitting flat on bottom pan. Using slotted holes as a guide, mark and drill two 1/8" holes and secure pump with two #10 screws (provided).
 - Rotate pump cord as shown



Caution: Rotate pump through wire clip making sure cord does not touch water in either the bottom pan or the pad frame.

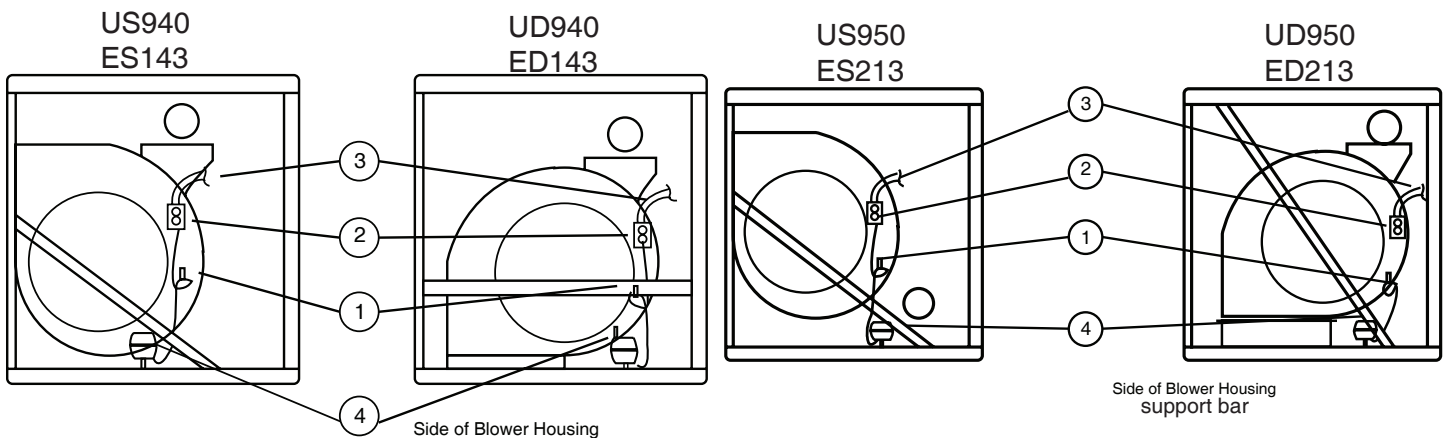
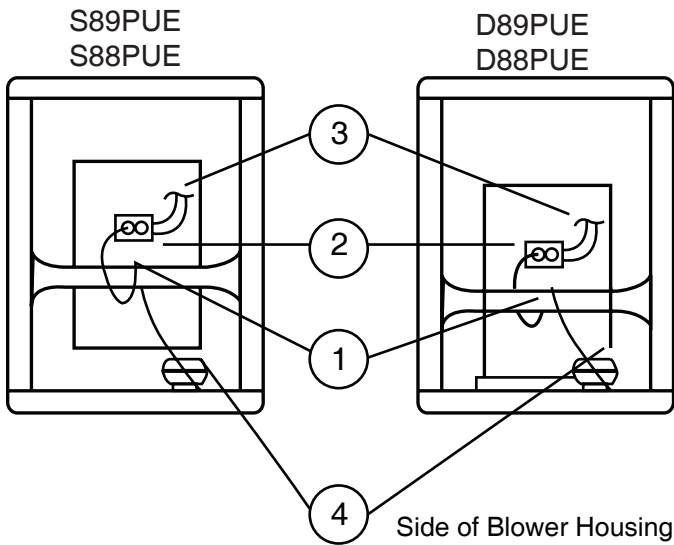

» Troubleshooting

The following troubleshooting guide is intended to address the most common symptoms and is by no means exhaustive.

If symptoms persist, call a qualified serviceman. Electrical work should be completed by a certified electrician. Turn off all power to the cooler before attempting to troubleshoot any of the following symptoms.

Symptom	Possible Causes	Remedy
Unit fails to start or deliver air	<ol style="list-style-type: none"> 1.No electrical power to unit <ol style="list-style-type: none"> A. Fuse blown B. Circuit breaker tripped C. Cord(s) damaged or unplugged 2.Belt improperly adjusted or broken 3.Motor overheated and/or frozen <ol style="list-style-type: none"> A. Belt too tight or broken B. Blower wheel bearings dry/shaft frozen C. Motor overloaded D. Faulty wiring or shorts 	<ol style="list-style-type: none"> 1.Check power <ol style="list-style-type: none"> A. Replace fuse* B. Reset breaker* C. Plug in cord or replace *If condition persist call electrician 2.Adjust belt tension 3.Replace motor <ol style="list-style-type: none"> A. Adjust belt tension or replace B. Lubricate or replace blower bearings C. Using ammeter, adjust motor to full load nameplate amps D. Call electrician
Unit starts but air delivery inadequate	<ol style="list-style-type: none"> 1.Lack of sufficient air exhaust 2.Motor underloaded (ducted units only) 3.Belt too loose 	<ol style="list-style-type: none"> 1. Open windows or doors to increase ventilation 2. Using ammeter, adjust motor to full load nameplate amps 3. Adjust belt tension or replace if needed
Inadequate cooling	<ol style="list-style-type: none"> 1.Inadequate exhaust in building 2.Air registers improperly positioned 3.Insufficient water/pad not wet <ol style="list-style-type: none"> A. Pads plugged B. Dry or open spots on pads C. Through holes clogged D. Pump not working E. Loose connections in water system F. Distributor clogged or corroded G. Insufficient bleed-off water H. Pump basket clogged 	<ol style="list-style-type: none"> 1.Open windows or doors to increase ventilation 2.Adjust to direct air as desired or Install lower restriction registers 3.Check water distribution system <ol style="list-style-type: none"> A. Replace pads B. Repack pads C. Clean troughs and unplug holes D. Disconnect pump. Clean impeller housing of foreign matter and reinstall E. Check for leaks and correct F. Clean or replace bleed-off kit G. Reset or replace bleed-off kit H. Clean or replace
Motor cycles or fails to operate	<ol style="list-style-type: none"> 1. Excessive belt tension 2. Blower shaft tight or frozen 3. Motor overloaded 4. Incorrect sheave adjustment 5. Pulleys misaligned 	<ol style="list-style-type: none"> 1.Adjust belt tension 2.Lubricate blower bearings 3.Correct- do not exceed motor nameplate amps 4.Serviceman should correct 5.Check and correct alignment
Water draining form overflow standpipe	<ol style="list-style-type: none"> 1.Float arm improperly adjusted 2.Seat in float valve leaking 3.Standpipe not tight 	<ol style="list-style-type: none"> 1. Adjust float 2. Replace float valve 3. Tighten standpipe
Knocking or banging sound	<ol style="list-style-type: none"> 1. Bearings dry 2. Wheel rubbing blower housing or rotating off-balance 3. Loose parts 	<ol style="list-style-type: none"> 1. Lubricate blower bearings or replace if badly worn 2. Inspect blower shaft, collars, belt and pulley alignment and motor mounting 3. Resecure or reconnect
Blower shakes or rattles	<ol style="list-style-type: none"> 1. Belt or pulley loose 	<ol style="list-style-type: none"> 1. Inspect and adjust, or replace belt and/or pulley as needed
Excessive humidity in building	<ol style="list-style-type: none"> 1. Inadequate exhaust 	<ol style="list-style-type: none"> 1. Open doors or windows to increase ventilation
Musty or unpleasant odor	<ol style="list-style-type: none"> 1. Stale or stagnant water in reservoir 2. Pads mildewed or clogged 3. Pads not completely wet before cooler is turned on 	<ol style="list-style-type: none"> 1.Drain, flush and clean reservoir. install bleed-off kit 2. Check Bleed-off setting. REplace pads 3.Turn on water before starting unit.

As The World Leader in Evaporative Cooling Technology and Innovation, Impco, Inc. is continually involved in the process of product improvement. In order to best meet your needs and continue to offer the most efficient and innovative cooling solutions, we rely on your feedback.

Whatever your cooling needs, we want to learn about your experience with this cooler, or any of our products, brands or team members.

Please contact us in the manner most convenient for you. We look forward to hearing from you.

email: customerservice@impcoaircoolers.com
www.impcoaircoolers.com

EVAPORATIVE COOLER LIMITED WARRANTY

Impco extends this limited warranty to the original purchaser of an Evaporative Cooler installed and used under normal conditions.

I. Five Year Warranty covers wet section cabinet rust out only. At our option, we will exchange or repair the wet section bottom pan assembly should any water leakage occur through the base assembly due to rust out during the first five years after date of initial purchase.

II. One Year Coverage-applies to all components (e.g. motor, pump, float, bearings). We will exchange any part (except cooler pads), which fails as a result of original material or workmanship during the first year after date of initial purchase.

III. What this Warranty Does Not Cover:

a. We are not responsible for any damage or malfunction unless a result of original material or workmanship. Damage or malfunction, which is not covered by this warranty, includes, but is not limited to, water damage to the motor, abuse, misuse, alteration, improper installation/maintenance/operation or transportation damage.

b. This warranty does not cover any failure or damage that results from unauthorized modification or service; or from the use of products or replacement parts other than those from Impco; including, but not limited to, motors and pumps.

c. Mineral accumulations, dirt and dust on the pads are not defects and are excluded from this warranty. Cooling pads are a disposable item and their life span depends on local conditions.

d. This warranty does not cover the cost of service call at the site of installation to diagnose cause of trouble, the cost of labor or mileage allowance to or from site to replace a defective part, or freight/postage on any exchange.

IV. To obtain service under this warranty, contact the dealer where you purchased the cooler. As a final step, or if you cannot locate your dealer, contact Impco Customer Service. Include your name, full address and phone number; the servicing dealer involved, the model and serial numbers of your cooler; the date of installation; and a description of your problem.

This warranty is the only warranty extended by Impco to suppliers and/or consumer purchasers of this evaporative cooler. Impco disclaims all other warranties, express or implied, that arise by the operation of the law, except that implied warranties of merchantability of fitness for a particular purpose are limited to the duration of the warranty period. Impco shall not be liable for any incidental or consequential damage, which may have resulted from any alleged breach of warranty.

Some states do not allow limitations on how long an implied warranty lasts or the exclusion or limitation of incidental or consequential damages, so the above limitations or exclusions stated above may not apply to you.

This warranty gives you specific legal rights, and you may have other rights, which vary from state to state.

V. Do not use cooler cleaners, cooler treatments, or other additives in this evaporative cooler. The use of any of these products will void your warranty and may impair the life of your evaporative cooler.



NOTE: There will be a slight odor that may be noticed during the initial start-up. The odor will disappear within the first few days of operation if proper bleed-off is used as instructed.

Since Impco follows a policy of continuous product improvement, it reserves the right to change design and specifications without prior notice or liability.

Impco

email: customerservice@impcoaircoolers.com

www.impcoaircoolers.com

impco.

email: customerservice@impcoaircoolers.com, Website: www.impcoaircoolers.com